



High Temperature Low Flow Indicator



General Description

Smartflow High Temperature Flow Indicators are designed to show the presence of flow in very low flow applications. This high temperature indicator comprises high-visibility impeller and robust flow body designed for punishing duty.

High Temperature, Low Flow Indicators are ideal for use in critical injection mold cooling circuits such as bubblers or baffles where flow is restricted and effective cooling is essential.

Burger & Brown Engineering recommends using only extremely clean cooling water through the attached channels to reduce the buildup of deposits that build up easily in high temperature applications. Scale deposits can coat the inside of cooling water channels effectively creating barrier insulation in water lines preventing efficient heat transfer.

Features and Benefits

- ◆ Compact size works well in restricted-space locations.
- ◆ Bi-Directional - flow indicator works with flow from either direction simplifying installation.
- ◆ 204°C (400°F) Temperature Rating allows installation into high temperature applications.
- ◆ 17.2bar (250psi) Pressure Rating satisfies most pressurized water system requirements.
- ◆ Economical for use in many locations throughout the plant.

Model Numbers

Model No.	Inlet Size
HTLFI3-A-40	3/8"NPT
HTLFI3B-A-40	3/8"BSPP

Wetted Parts and Materials

Flow Body..... Stainless Steel
 Viewing Window High Temperature Glass
 Impeller..... High Temperature Polymer
 Shaft Stainless Steel
 Pin Stainless Steel
 O-Ring PTFE

Specifications

Threaded Connections 3/8"NPT or BSPP
 Operating Temperature max..... 204°C (400°F)
 Operating Pressure max..... 17.2bar (250psi)
 Flow Range 0.3 - 4 LPM (0.08 - 1 GPM)



Use with Smartflow High Temperature Flow Regulator when precise flow control is needed.

Follow the QR Code to watch our flow balancing and optimization animation

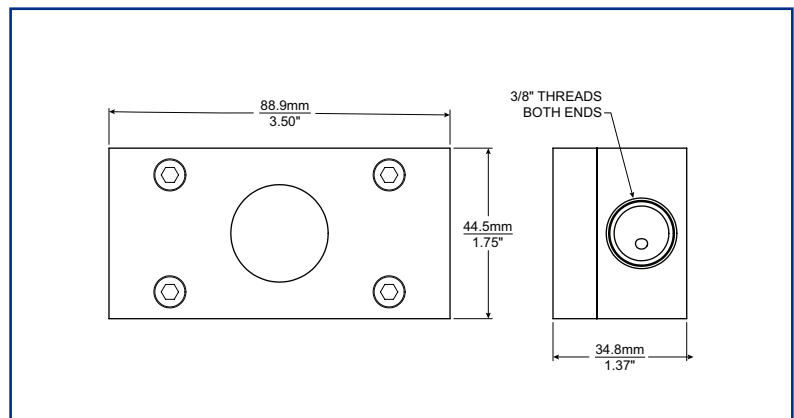

4500 E 142nd Street
 Grandview, MO 64030 USA
 Tel: 816-878-6675
 www.smartflow-usa.com

Design and specifications are subject to change without notice.



High Temperature Flow Regulator

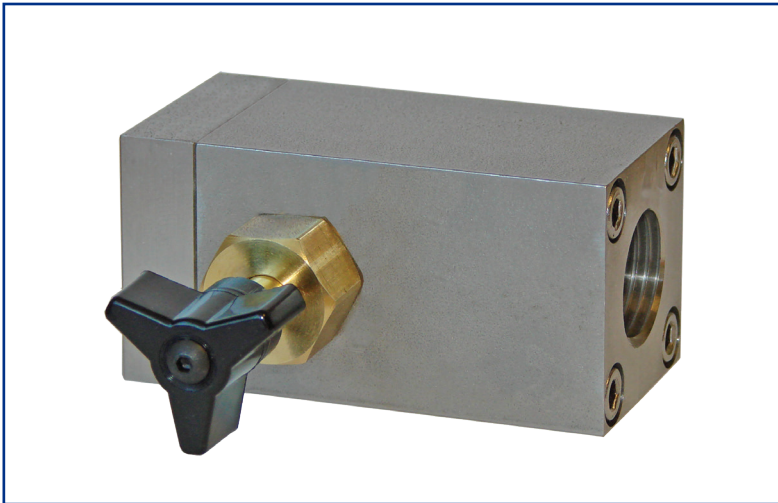

General Description

Smartflow High Temperature Flow Regulator is a manual needle valve specifically designed for high temperature cooling applications. Maximum pressure rating of 17.2bar (250psi) allows installation into many different cooling applications.

Fine manual control regulates the flow opening from wide open to fully closed. Flow body is comprised of corrosion-resistant stainless steel and brass components in addition to high temperature o-ring seals.

Burger & Brown Engineering recommends using extremely clean cooling media to reduce the incidence of scale build-up inside cooling lines. Scale may create a barrier to effective heat transfer preventing efficient cooling.

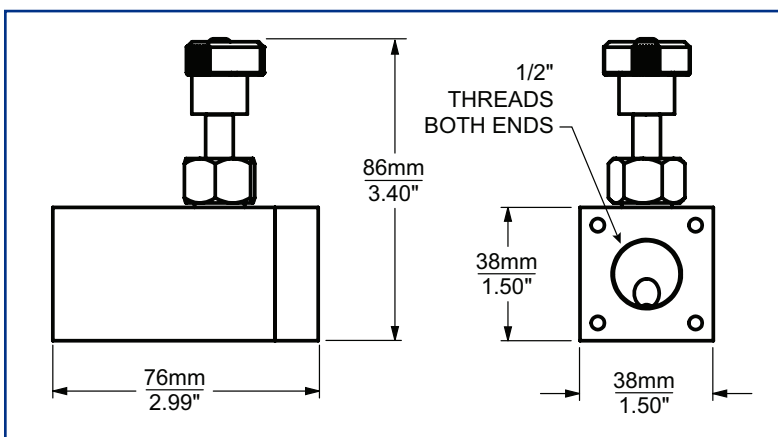

Caution!

Always use pipe thread sealant that is rated for use in high temperature applications when joining these components. We recommend Loctite #567 or equivalent.

Model Numbers

Model No.	Thread Size
HWFR4-A-NA	1/2"NPT
HWFR4B-A-NA	1/2"BSPP

Wetted Parts and Materials

Flow Body Stainless Steel
 Valve Stem Brass
 Valve Seat Stainless Steel
 O-Ring Viton

Specifications

Threaded Connections 1/2"NPT or BSPP
 Operating Temperature max. 204°C (400°F)
 Operating Pressure max. 17.2bar (250psi)

Combine High Temperature Flow Indicator and Flow Regulator

A reducing hex nipple is used to combine the Flow Indicator with the Flow Regulator on these pages. The result is a unique product that will precisely control the flow in critical injection mold cooling circuits. Indication of the presence of flow is challenging in high temperature circuits.

Three part numbers are required for the combination. See below.

Item	NPT	BSP
Flow Indicator	HTLFI3-A-40	HTLFI3B-A-40 (BSPP)
Reducing Hex Nipple (1/2" x 3/8")	HN-3-4-SS	HN-3B-4B-SS (BSPT)
Flow Regulator	HWFR4-A-NA	HWFR4B-A-NA (BSPP)

